

DATA SHEET

2322 640 5....

NTC thermistors, accuracy line

Product specification
Supersedes data of 4th September 1998
File under BCcomponents, BC02

2001 Sep 27

NTC thermistors, accuracy line

2322 640 5....

FEATURES

- Accurate over a wide temperature range (tolerance on B-value between 2.5% and 0.75%)
- Good stability over a long life
- Excellent price/performance ratio
- Flexible leads
- Low heat conductivity through 0.4 mm diameter Ni-leads.

APPLICATION

Temperature sensing and control.

DESCRIPTION

These thermistors have a negative temperature coefficient. The device consists of a chip with two tinned Ni-leads. The device is colour coded.

PACKAGING

The thermistors are packed in cardboard boxes; the smallest packaging quantity is 500 units.

MECHANICAL DATA

Marking

The thermistors are marked with coloured bands; see Fig.1 and Table 1.

Mounting

By soldering in any position.

QUICK REFERENCE DATA

PARAMETER	VALUE
Resistance value at 25 °C	2 to 470 kΩ
Tolerance on R ₂₅ -value	±5%; ±3%; ±2%; ±1%
Tolerance on B _{25/85} -value	±2.5 to ±0.75%
Maximum dissipation	100 mW
Response time	≈1.7 s
Operating temperature range at: zero dissipation (continuously) zero dissipation (for short periods) maximum dissipation (100 mW)	-40 to +125 °C ≤150 °C 0 to +55 °C
Climatic category	40/125/56
Mass	≈0.11 g

Outline

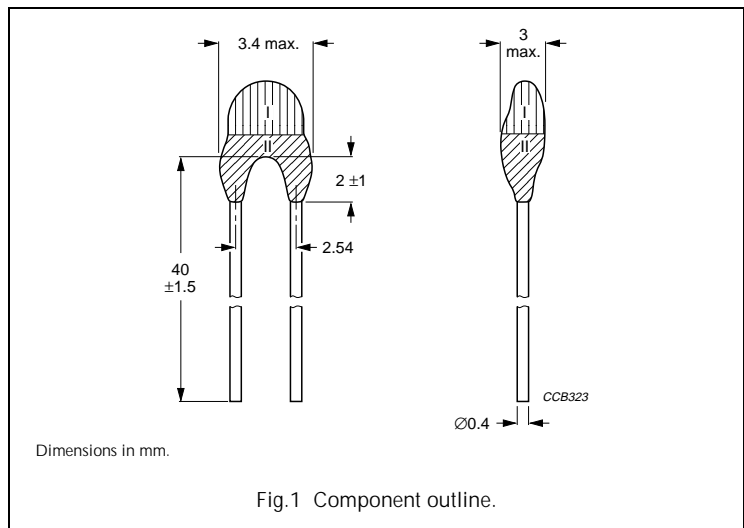

NTC thermistors, accuracy line

2322 640 5....

ORDERING INFORMATION

Table 1 R_{25} -values, catalogue numbers and coding; note 1

The thermistors have a 12-digit catalogue number starting with 2322 640 5. The subsequent 4 digits indicate the resistance value and tolerance.

R_{25} (k Ω)	$B_{25/85}$ -VALUE	CATALOGUE NUMBER 2322 640 5....				CODING (see Fig.1)	
		$R_{25} \pm 5\%$	$R_{25} \pm 3\%$	$R_{25} \pm 2\%$	$R_{25} \pm 1\%$	I	II
2	3528 K $\pm 0.5\%$	3202	6202	4202	5202	orange	orange
2.7	3977 K $\pm 0.75\%$	3272	6272	4272	5272	red	red
4.7	3977 K $\pm 0.75\%$	3472	6472	4472	5472	green	green
5	3977 K $\pm 0.75\%$	3502	6502	4502	5502	black	white
10	3977 K $\pm 0.75\%$	3103	6103	4103	5103	blue	blue
12	3740 K $\pm 2\%$	3123	6123	4123	–	yellow	yellow
22	3740 K $\pm 2\%$	3223	6223	4223	–	white	white
47	4090 K $\pm 1.5\%$	3473	6473	4473	–	black	black
68	4190 K $\pm 1.5\%$	3683	6683	4683	–	grey	grey
100	4190 K $\pm 1.5\%$	3104	6104	4104	5104	brown	brown
470	4570 K $\pm 1.5\%$	3474	6474	4474	–	violet	violet

Note

1. Extended range available on request.

NTC thermistors, accuracy line

2322 640 5....

Table 2 Resistance values at intermediate temperatures with R_{25} at 2 k Ω ; see also Table 1

T_{oper} (°C)	R_T/R_{25}	ΔR DUE TO B-TOLERANCE (%)	TC (%/K)	R_{25} (Ω)
				2322 640; see Table 7, note 1
				5.202
-40	23.3402	1.65	-6.06	46684
-35	17.3347	1.49	-5.84	34672
-30	13.0166	1.34	-5.62	26035
-25	9.8764	1.19	-5.42	19754
-20	7.5682	1.05	-5.23	15138
-15	5.8541	0.92	-5.05	11709
-10	4.5688	0.79	-4.87	9138
-5	3.5961	0.66	-4.71	7193
0	2.8533	0.54	-4.55	5707
5	2.2815	0.43	-4.40	4563
10	1.8376	0.31	-4.26	3675
15	1.4904	0.21	-4.12	2981
20	1.2169	0.10	-3.99	2434
25	1.0000	0.00	-3.87	2000
30	0.8266	0.10	-3.75	1653
35	0.6873	0.19	-3.63	1375
40	0.5746	0.28	-3.53	1149
45	0.4827	0.37	-3.42	965.0
50	0.4073	0.46	-3.32	814.7
55	0.3452	0.54	-3.23	690.5
60	0.2937	0.62	-3.14	587.5
65	0.2508	0.70	-3.05	501.7
70	0.2149	0.78	-2.97	429.8
75	0.1847	0.85	-2.89	369.5
80	0.1593	0.92	-2.81	318.6
85	0.1377	0.99	-2.73	275.5
90	0.1194	1.06	-2.66	238.9
95	0.1038	1.13	-2.59	207.6
100	0.09045	1.19	-2.53	180.9
105	0.07900	1.25	-2.46	158.0
110	0.06915	1.31	-2.40	138.3
115	0.06066	1.37	-2.34	121.3
120	0.05332	1.43	-2.29	106.6
125	0.04696	1.49	-2.23	93.9
130	0.04143	1.54	-2.18	82.9
135	0.03662	1.60	-2.13	73.3
140	0.03243	1.65	-2.08	64.9
145	0.02877	1.70	-2.03	57.5
150	0.02556	1.75	-2.33	51.1

NTC thermistors, accuracy line

2322 640 5....

Table 3 Resistance values at intermediate temperatures with R_{25} at 2.7 k Ω , 4.7 k Ω , 5 k Ω and 10 k Ω ; see also Table 1

T_{oper} (°C)	R_T/R_{25}	ΔR DUE TO B-TOLERANCE (%)	TC (%/K)	R_{25} (k Ω)			
				2322 640;see Table 7, note 1			
				5.272	5.472	5.502	5.103
-40	33.21	2.66	6.57	89.67	156.1	166.1	332.1
-35	23.99	2.41	6.36	64.77	112.8	120.0	240.0
-30	17.52	2.17	6.15	47.31	82.35	87.60	175.2
-25	12.93	1.94	5.95	34.91	60.77	64.65	129.3
-20	9.636	1.71	5.76	26.02	45.30	48.18	96.36
-15	7.250	1.50	5.58	19.58	34.08	36.25	72.50
-10	5.505	1.29	5.40	14.86	25.87	27.52	55.05
-5	4.216	1.08	5.24	11.38	19.81	21.08	42.16
0	3.255	0.89	5.08	8.790	15.30	16.28	32.56
5	2.534	0.70	4.92	6.842	11.91	12.67	25.34
10	1.987	0.52	4.78	5.366	9.340	9.936	19.87
15	1.570	0.34	4.64	4.239	7.378	7.849	15.70
20	1.249	0.17	4.50	3.372	5.869	6.244	12.49
25	1.000	0.00	4.37	2.700	4.700	5.000	10.00
30	0.8059	0.16	4.25	2.176	3.788	4.030	8.059
35	0.6535	0.32	4.13	1.764	3.072	3.267	6.535
40	0.5330	0.47	4.02	1.439	2.505	2.665	5.330
45	0.4372	0.62	3.91	1.180	2.055	2.186	4.372
50	0.3605	0.77	3.80	0.973	1.694	1.803	3.606
55	0.2989	0.91	3.70	0.807	1.405	1.494	2.989
60	0.2490	1.05	3.60	0.672	1.170	1.245	2.490
65	0.2084	1.18	3.51	0.562	0.9797	1.042	2.084
70	0.1753	1.31	3.42	0.473	0.8239	0.8765	1.753
75	0.1481	1.44	3.33	0.399	0.6960	0.7405	1.481
80	0.1256	1.57	3.25	0.339	0.5905	0.6282	1.256
85	0.1070	1.69	3.16	0.289	0.5031	0.5352	1.070
90	0.09154	1.81	3.09	0.247	0.4303	0.4577	0.9154
95	0.07860	1.93	3.01	0.212	0.3694	0.3930	0.7860
100	0.06773	2.04	2.94	0.182	0.3183	0.3387	0.6773
105	0.05858	2.15	2.87	0.158	0.2753	0.2929	0.5858
110	0.05083	2.26	2.80	0.137	0.2389	0.2542	0.5083
115	0.04426	2.37	2.73	0.1195	0.2080	0.2213	0.4426
120	0.03866	2.47	2.67	0.1044	0.1817	0.1933	0.3866
125	0.03387	2.57	2.61	0.0915	0.1592	0.1694	0.3387
130	0.02977	2.67	2.55	0.0804	0.1399	0.1488	0.2977
135	0.02624	2.77	2.49	0.0709	0.1233	0.1312	0.2624
140	0.02319	2.86	2.43	0.0626	0.1090	0.1160	0.2319
145	0.02055	2.96	2.38	0.0555	0.0966	0.1028	0.2055
150	0.01826	3.05	2.33	0.0493	0.0858	0.0913	0.1826

NTC thermistors, accuracy line**2322 640 5....****Table 4** Resistance values at intermediate temperatures with R_{25} at 12 k Ω and 22 k Ω ; see also Table 1

T_{amb} (°C)	R_T/R_{25}	ΔR DUE TO B-TOLERANCE (%)	TC (%/K)	R_{25} (k Ω)	
				2322 640; see Table 7, note 1	
				5.123	5.223
-40	25.78	6.81	6.09	309.4	567.2
-35	19.13	6.16	5.89	229.5	420.8
-30	14.32	5.53	5.70	171.8	315.0
-25	10.82	4.93	5.52	129.8	238.0
-20	8.245	4.35	5.35	98.93	181.4
-15	6.335	3.80	5.19	76.02	139.4
-10	4.907	3.26	5.03	58.88	107.9
-5	3.830	2.74	4.88	45.95	84.25
0	3.011	2.24	4.73	36.13	66.24
5	2.384	1.76	4.60	28.60	52.45
10	1.900	1.30	4.46	22.80	41.81
15	1.525	0.85	4.34	18.30	33.55
20	1.231	0.42	4.21	14.77	27.09
25	1.000	0.00	4.10	12.00	22.00
30	0.8170	0.41	3.98	9.804	17.97
35	0.6712	0.80	3.88	8.054	14.77
40	0.5543	1.19	3.77	6.652	12.20
45	0.4602	1.57	3.67	5.522	10.12
50	0.3839	1.94	3.57	4.607	8.447
55	0.3219	2.30	3.48	3.862	7.081
60	0.2710	2.65	3.39	3.252	5.963
65	0.2293	2.99	3.30	2.751	5.044
70	0.1947	3.33	3.22	2.337	4.284
75	0.1661	3.66	3.14	1.993	3.654
80	0.1422	3.98	3.06	1.707	3.129
85	0.1223	4.29	2.99	1.467	2.690
90	0.1055	4.60	2.92	1.266	2.321
95	0.09135	4.90	2.85	1.096	2.010
100	0.07937	5.19	2.78	0.9524	1.746
105	0.06919	5.48	2.71	0.8302	1.522
110	0.06050	5.76	2.65	0.7260	1.331
115	0.05307	6.04	2.59	0.6369	1.168
120	0.04670	6.31	2.53	0.5604	1.027
125	0.04121	6.57	2.47	0.4945	0.9065

NTC thermistors, accuracy line

2322 640 5....

Table 5 Resistance values at intermediate temperatures with R_{25} at 47 k Ω ; see also Table 1

T_{amb} (°C)	R_T/R_{25}	ΔR DUE TO B-TOLERANCE (%)	TC (%/K)	R_{25} (k Ω)
				2322 640; see Table 7, note 1
				5.473
-40	33.81	5.55	6.55	1589
-35	24.50	5.02	6.34	1151
-30	17.93	4.52	6.15	842.8
-25	13.25	4.03	5.96	622.6
-20	9.875	3.56	5.78	464.1
-15	7.425	3.10	5.61	349.0
-10	5.630	2.67	5.45	264.6
-5	4.304	2.24	5.29	202.3
0	3.315	1.84	5.14	155.8
5	2.573	1.44	4.99	120.9
10	2.011	1.07	4.85	94.53
15	1.583	0.70	4.72	74.40
20	1.254	0.34	4.59	58.95
25	1.000	0.00	4.46	47.00
30	0.8024	0.33	4.34	37.71
35	0.6474	0.66	4.23	30.43
40	0.5255	0.98	4.12	24.70
45	0.4288	1.28	4.01	20.15
50	0.3518	1.59	3.91	16.53
55	0.2901	1.88	3.81	13.63
60	0.2403	2.17	3.71	11.30
65	0.2001	2.45	3.62	9.404
70	0.1674	2.72	3.53	7.865
75	0.1406	2.99	3.44	6.607
80	0.1186	3.25	3.36	5.573
85	0.1004	3.51	3.28	4.721
90	0.08542	3.76	3.20	4.015
95	0.07292	4.00	3.13	3.427
100	0.06248	4.24	3.06	2.936
105	0.05372	4.47	2.98	2.525
110	0.04635	4.70	2.92	2.179
115	0.04013	4.93	2.85	1.886
120	0.03485	5.15	2.79	1.638
125	0.03037	5.36	2.73	1.427
130	0.02654	5.57	2.67	1.247
135	0.02326	5.78	2.61	1.093
140	0.02044	5.98	2.55	0.9608
145	0.01802	6.18	2.50	0.8468
150	0.01592	6.37	2.44	0.7483

NTC thermistors, accuracy line

2322 640 5....

Table 6 Resistance values at intermediate temperatures with R_{25} at 68 k Ω and 100 k Ω ; see also Table 1

T_{amb} (°C)	R_T/R_{25}	ΔR DUE TO B-TOLERANCE (%)	TC (%/K)	R_{25} (k Ω)	
				2322 640; see Table 7, note 1	
				6.683	6.104
-40	36.66	5.69	6.70	2493	3666
-35	26.38	5.15	6.49	1794	2638
-30	19.17	4.63	6.29	1303	1917
-25	14.06	4.13	6.10	956.2	1406
-20	10.41	3.65	5.92	708.0	1041
-15	7.779	3.18	5.74	528.9	777.9
-10	5.861	2.73	5.57	398.5	586.1
-5	4.453	2.30	5.41	302.8	445.3
0	3.409	1.88	5.26	231.8	340.9
5	2.631	1.48	5.11	178.9	263.1
10	2.044	1.09	4.97	139.0	204.4
15	1.600	0.72	4.83	108.8	160.0
20	1.261	0.35	4.70	85.74	126.1
25	1.000	0.00	4.57	68.00	100.0
30	0.7981	0.34	4.45	54.27	79.81
35	0.6408	0.67	4.35	43.57	64.08
40	0.5175	1.00	4.22	35.19	51.74
45	0.4202	1.32	4.11	28.57	42.02
50	0.3431	1.63	4.00	23.33	34.31
55	0.2816	1.93	3.90	19.15	28.16
60	0.2322	2.22	3.80	15.79	23.22
65	0.1925	2.51	3.71	13.09	19.25
70	0.1602	2.79	3.62	10.90	16.03
75	0.1340	3.06	3.53	9.114	13.40
80	0.1126	3.33	3.45	7.655	11.26
85	0.09496	3.59	3.36	6.457	9.496
90	0.08042	3.85	3.28	5.469	8.042
95	0.06837	4.10	3.21	4.649	6.837
100	0.05835	4.35	3.13	3.968	5.835
105	0.04998	4.59	3.06	3.399	4.998
110	0.04296	4.82	2.99	2.921	4.296
115	0.03705	5.05	2.92	2.519	3.705
120	0.03206	5.28	2.86	2.180	3.206
125	0.02783	5.50	2.80	1.892	2.783

NTC thermistors, accuracy line

2322 640 5....

Table 7 Resistance values at intermediate temperatures with R_{25} at 470 k Ω ; see also Table 1

T_{amb} (°C)	R_T/R_{25}	ΔR DUE TO B-TOLERANCE (%)	TC (%/K)	R_{25} (k Ω)
				2322 640; note 1
				5.474
-40	48.62	6.22	7.13	22850
-35	34.19	5.63	6.91	16068
-30	24.28	5.06	6.71	11413
-25	17.42	4.51	6.52	8185
-20	12.61	3.98	6.33	5926
-15	9.211	3.47	6.15	4329
-10	6.788	2.98	5.98	3190
-5	5.045	2.51	5.82	2371
0	3.781	2.06	5.66	1776
5	2.855	1.62	5.50	1342
10	2.173	1.19	5.36	1021
15	1.666	0.78	5.22	783.0
20	1.286	0.38	5.08	604.6
25	1.000	0.00	4.95	470.0
30	0.7825	0.37	4.82	367.8
35	0.6163	0.74	4.70	289.6
40	0.4883	1.09	4.59	229.5
45	0.3892	1.44	4.47	182.9
50	0.3120	1.77	4.36	146.7
55	0.2515	2.10	4.26	118.2
60	0.2038	2.43	4.15	95.80
65	0.1660	2.74	4.06	78.03
70	0.1359	3.05	3.96	63.88
75	0.1118	3.35	3.87	52.55
80	0.09240	3.64	3.78	43.43
85	0.07670	3.93	3.69	36.05
90	0.06395	4.21	3.61	30.06
95	0.05354	4.48	3.53	25.16
100	0.04501	4.75	3.45	21.15
105	0.03798	5.01	3.37	17.85
110	0.03218	5.27	3.30	15.12
115	0.02736	5.52	3.23	12.86
120	0.02335	5.77	3.16	10.97
125	0.01999	6.01	3.09	9.396

Note to Tables 2 through 7

1. Replace dot in last 5 digits of catalogue number by a number according to the following details and depending on tolerance on required R_{25} -value: 4 for a tolerance of $\pm 2\%$; 6 for a tolerance of $\pm 3\%$; 3 for a tolerance of $\pm 5\%$; 2 for a tolerance of $\pm 10\%$.

NTC thermistors, accuracy line**2322 640 5....****ELECTRICAL CHARACTERISTICS**

Unless otherwise stated, measurements are in accordance with "IEC publication 60539"; see also Table 1.

PARAMETER	VALUE
Standard selection tolerance on R_{25}	$\pm 5\%$; $\pm 3\%$; $\pm 2\%$; $\pm 1\%$
Climatic category	40/125/56
Maximum dissipation	100 mW
Dissipation factor δ	2.2 mW/K
Response time; note 1	1.7 s
Thermal time constant τ	13 s
Operating temperature range (see Fig.2):	
at zero dissipation (continuously)	-40 to +125 °C
at zero dissipation (for short periods); note 2	≤ 150 °C
at maximum dissipation	0 to +55 °C

Notes

1. Response time in silicone oil MS200/50. This is the time needed for the sensor to reach 63.2% of the total temperature difference when subjected to a temperature change from 25 °C in air to 85 °C in oil.
2. Valid for all types with the exception of 2322 640 5.474.

NTC thermistors, accuracy line

2322 640 5....

Derating

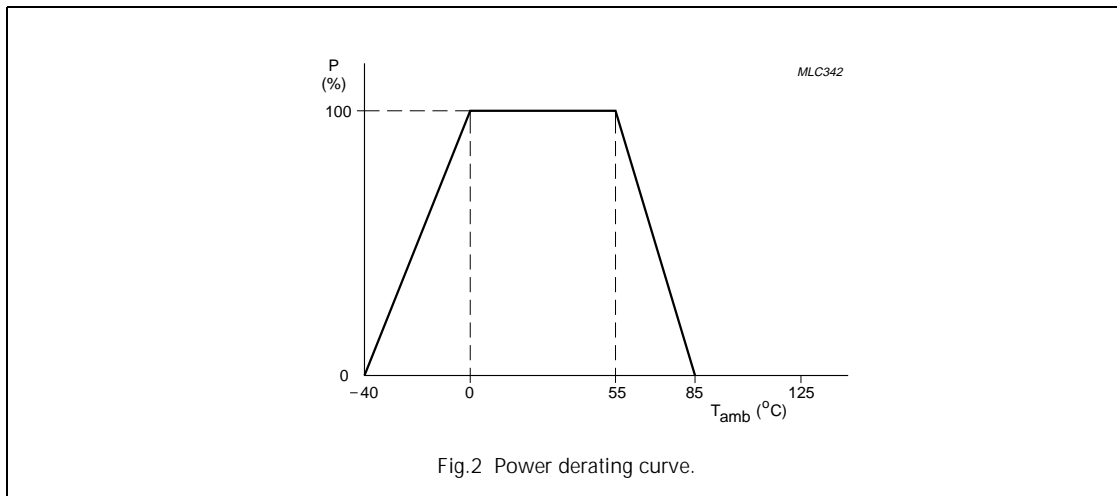

Long term stability

